

Altivar 31●●●T

Variable speed drives
for asynchronous motors
Traverse control

Programming manual
Traverse control



Table of contents

Warnings	2
Using the traverse control programming manual	3
Factory configuration	4
Function compatibility	5
List of functions which can be assigned to inputs/outputs	6
Settings menu SEt- and motor control menu drC-	7
I/O menu I-O-	8
Control menu CtL-	9
Application functions menu FUn-	11
Display menu SUP-	22
Configuration/Settings table	23
Communication variables	24

NOTE: Please also refer to the "Installation Manual" and the "Altivar 31 Programming Manual".

When the drive is powered up, the power components and some of the control components are connected to the line supply. It is extremely dangerous to touch them. *The drive cover must be kept closed.*

In general, *the drive power supply must be disconnected* before any operation on either the electrical or mechanical parts of the installation or machine.

After the ALTIVAR has been switched off and the display has disappeared completely, *wait for 10 minutes before working on the equipment.* This is the time required for the capacitors to discharge.

The motor can be stopped during operation by inhibiting start commands or the speed reference while the drive remains powered up. If personnel safety requires prevention of sudden restarts, this electronic locking system is not sufficient: *fit a cut-off on the power circuit.*

The drive is fitted with safety devices which, in the event of a fault, can shut down the drive and consequently the motor. The motor itself may be stopped by a mechanical blockage. Finally, voltage variations, especially line supply failures, can also cause shutdowns.

If the cause of the shutdown disappears, there is a risk of restarting which may endanger certain machines or installations, especially those which must conform to safety regulations.

In this case the user must take precautions against the possibility of restarts, in particular by using a low speed detector to cut off power to the drive if the motor performs an unprogrammed shutdown.

The drive must be installed and set up in accordance with both IEC international and national standards. Bringing the device into conformity is the responsibility of the systems integrator who must observe the EMC directive among others within the European Union.

The specifications contained in this document must be applied in order to comply with the essential requirements of the EMC directive.

The Altivar 31 must be considered as a component: it is neither a machine nor a device ready for use in accordance with European directives (machinery directive and electromagnetic compatibility directive). It is the responsibility of the end user to ensure that the machine meets these standards.

The drive must not be used as a safety device for machines posing a potential risk of material damage or personal injury (lifting equipment, for example). In such applications, overspeed checks and checks to ensure that the trajectory remains under constant control must be made by separate devices which are independent of the drive.

The products and equipment described in this document may be changed or modified at any time, either from a technical point of view or in the way they are operated. Their description can in no way be considered contractual.

Using the traverse control programming manual

This document should be used in conjunction with the Altivar 31 programming manual. It describes functions and parameters that are additional or different to the Altivar 31.

Differences from the Altivar 31

- The PowerSuite software workshop cannot be used with the Altivar31●●●T
- Different factory configuration (see page [4](#))
- Compatibility of the different functions (see page [5](#))
- Assignments of the different analog/logic output and relays (see page [8](#))
- Diagrams of the different reference channel (see pages [9](#) and [10](#))
- Application functions menu FUn-:
 - Addition of the Traverse control sub-menu: tCO- (see page [17](#))
 - Different PI Regulator sub-menu: PI- (see page [20](#))
 - Deletion of Brake control menu: bLC-
 - Deletion of Management of limit switch menu: LSt-
- Display menu SUP
 - Addition of parameters relating to the PI function and the traverse control function (see page [22](#))

Factory configuration

Factory settings

Factory settings which are specific to the Altivar●●●T are underlined.

The Altivar 31 is factory-set for the most common operating conditions:

- Display: Drive ready (rdY) with motor stopped, and motor frequency with motor running
- **Motor** frequency (bFr): 50 Hz
- Constant torque application (UFt = L).
- Suppression of the speed loop filter (SrF = YES)
- Normal stop mode on deceleration ramp (Stt = rMP).
- Stop mode in the event of a fault: Freewheel
- Linear ramps (ACC, dEC): 3 seconds
- Low speed (LSP): 0 Hz
- High speed (HSP): 50 Hz
- Motor thermal current (ItH) = Nominal motor current (value depending on drive rating)
- Standstill injection braking current (SdC1) = 0.7 x nominal drive current, for 0.5 seconds
- Automatic adaptation of the deceleration ramp in the event of overvoltage on braking
- No automatic restarting after a fault
- Switching frequency 4 kHz
- Logic inputs:
 - LI1: Forward, 2-wire transition detection control, non-reversing, inactive on the ATV31●●●●●AT.
 - LI2: Inactive (not assigned)
 - LI3: Traverse control command
 - LI4: Inactive (not assigned)
 - LI5 - LI6: Inactive (not assigned)
- Analog inputs:
 - AI1: Speed reference 0-10 V, inactive on ATV 31●●●●●AT drives (not assigned)
 - AI2: Summed speed reference input 0±10 V
 - AI3: 4-20 mA inactive (not assigned)
- Relay R1: The contact opens in the event of a fault (or drive off)
- Relay R2: Inactive (not assigned)
- Analog output AOC: 0-20 mA inactive (not assigned)

ATV 31●●●●●AT range

When they leave the factory, ATV 31●●●●●AT drives are supplied with local control activated: the RUN, STOP buttons and the drive potentiometer are active. Both logic input LI1 and analog input AI1 are inactive (not assigned).

If the above values are compatible with the application, the drive can be used without changing the settings.

Function compatibility

Incompatible functions

The following functions will be inaccessible or deactivated in the cases described below:

Automatic restart

This is only possible for 2-wire level detection control (tCC = 2C and tCt = LEL or PFO).

Flying restart

This is only possible for 2-wire level detection control (tCC = 2C and tCt = LEL or PFO).

This function is locked if the automatic DC injection on stopping is configured as Continuous (AdC = Ct).

Reverse

On the ATV31...AT range only, this function is locked if local control is active (tCC = LOC).

Function compatibility table

The choice of application functions may be limited by the number of I/O and by the fact that some functions are incompatible with one another. Functions which are not listed in this table are fully compatible.

If there is an incompatibility between functions, the first function configured will prevent the remainder being configured.

To configure a function, first check that functions which are incompatible with it are unassigned, especially those which are assigned in the factory setting.

	Summed inputs (factory setting)	+/- speed (1)	Traverse control (factory setting)	Preset speeds	PI regulator	JOG operation	Motor switching	DC injection stop	Quick stop	Freewheel stop
Summed inputs (factory setting)	●			↑		↑				
+/- speed (1)	●	●		●	●	●				
Traverse control (factory setting)			●				↑			
Preset speeds	↑	●		●	●	↑				
PI regulator		●		●	●	●				
JOG operation	↑	●		↑	●	●				
Motor switching			↑				●	●		
DC injection stop							●	●		↑
Quick stop									●	↑
Freewheel stop								↑	↑	●

(1) Excluding special application with reference channel Fr2 (see diagrams on pages 9 and 10)

● Incompatible functions □ Compatible functions ■ N/A

Priority functions (functions which cannot be active at the same time):

← ↑ The function indicated by the arrow has priority over the other.

Stop functions have priority over run commands.

Speed references via logic command have priority over analog references.

List of functions which can be assigned to inputs/outputs

Logic inputs

The assignments Limit switch forward LAF and Limit switch reverse LAr are not available on the ATV31●●●T.
Addition of assignments to the "Traverse control" function.

Analog inputs

Unchanged.

Analog/logic output

Addition of assignments to the "Traverse control" function.
No "brake sequence" assignment.

Relay

Addition of assignments to the "Traverse control" function.
No "brake sequence" assignment.

Settings menu SET- and motor control menu drC-

Settings menu SET-

Unchanged.

Motor control menu drC-

Unchanged except for the factory setting of parameter UFL which is now "L" and the factory setting of parameter SrF which is now "YES".

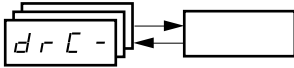

Code	Description	Adjustment range	Factory setting
UFL	<p>Selection of the type of voltage/frequency ratio</p> <p><i>L</i> : Constant torque for motors connected in parallel or special motors <i>P</i> : Variable torque: Pump and fan applications <i>n</i> : Sensorless flux vector control for constant torque applications <i>nLd</i> : Energy saving, for variable torque applications not requiring high dynamics (behaves in a similar way to the P ratio at no load and the n ratio on load).</p> <p>Voltage</p>		L
SrF	<p>Suppression of the speed loop filter</p> <p><i>nD</i> : The speed loop filter is active (prevents the reference being exceeded). <i>YES</i> : The speed loop filter is suppressed (in position control applications, this reduces the response time and the reference may be exceeded).</p>		YES

I/O menu I-O-

Unchanged except for the analog/logic output and relay assignments:

- No "brake sequence" assignment
- Addition of the "end of reel" assignment
- Addition of the "counter wobble synchronization" assignment

Code	Description	Factory setting
<i>d 0</i>	Analog/logic output AOC/AOV <i>n 0</i> : Not assigned <i>D C r</i> : Motor current. 20 mA or 10 V corresponds to twice the nominal drive current <i>D F r</i> : Motor frequency. 20 mA or 10 V corresponds to the maximum frequency tFr <i>D E r</i> : Motor torque. 20 mA or 10 V corresponds to twice the nominal motor torque <i>D P r</i> : Power supplied by the drive. 20 mA or 10 V corresponds to twice the nominal drive power. Making the following assignments (1) will transform the analog output to a logic output (see the diagram in the Installation Manual): <i>F L t</i> : Drive fault <i>r U n</i> : Drive running <i>F t A</i> : Frequency threshold reached (Ftd parameter in the SEt- menu) <i>F L A</i> : High speed (HSP) reached <i>C t A</i> : Current threshold reached (Ctd parameter in the SEt- menu) <i>S r A</i> : Frequency reference reached <i>E S A</i> : Motor thermal threshold reached (ttd parameter in the SEt- menu) <i>A P L</i> : Loss of 4-20 mA signal, even if LFL = nO <i>E b 0</i> : <u>End of reel</u> (parameter tbO, page 17) <i>C L 0</i> : <u>"Counter wobble" synchronization</u> . To be configured on the thread guide drive (master) only. See page 15 The logic output is at state 1 (24 V) when the selected assignment is active, with the exception of FLt (state 1 if the drive is not faulty).  (1) With these assignments, configure AO1t = 0A .	nO
<i>r 1</i>	Relay r1 <i>n 0</i> : Not assigned <i>F L t</i> : Drive fault <i>r U n</i> : Drive running <i>F t A</i> : Frequency threshold reached (Ftd parameter in the SEt- menu) <i>F L A</i> : High speed (HSP) reached <i>C t A</i> : Current threshold reached (Ctd parameter in the SEt- menu) <i>S r A</i> : Frequency reference reached <i>E S A</i> : Motor thermal threshold reached (ttd parameter in the SEt- menu) <i>A P L</i> : Loss of 4-20 mA signal, even if LFL = nO <i>E b 0</i> : <u>End of reel</u> (parameter tbO, page 17) <i>C L 0</i> : <u>"Counter wobble" synchronization</u> . To be configured on the thread guide drive (master) only. See page 15 The relay is powered up when the selected assignment is active, with the exception of FLt (powered up if the drive is not faulty).	FLt
<i>r 2</i>	Relay r2 <i>n 0</i> : Not assigned <i>F L t</i> : Drive fault <i>r U n</i> : Drive running <i>F t A</i> : Frequency threshold reached (Ftd parameter in the SEt- menu) <i>F L A</i> : High speed (HSP) reached <i>C t A</i> : Current threshold reached (Ctd parameter in the SEt- menu) <i>S r A</i> : Frequency reference reached <i>E S A</i> : Motor thermal threshold reached (ttd parameter in the SEt- menu) <i>A P L</i> : Loss of 4-20 mA signal, even if LFL = nO <i>E b 0</i> : <u>End of reel</u> (parameter tbO, page 17) <i>C L 0</i> : <u>"Counter wobble" synchronization</u> . To be configured on the thread guide drive (master) only. See page 15 The relay is powered up when the selected assignment is active, with the exception of FLt (powered up if the drive is not faulty).	nO

Control menu CtL-

Menu unchanged, but different diagrams: summed input placed after the PI

Reference channel for LAC = L1 or L2

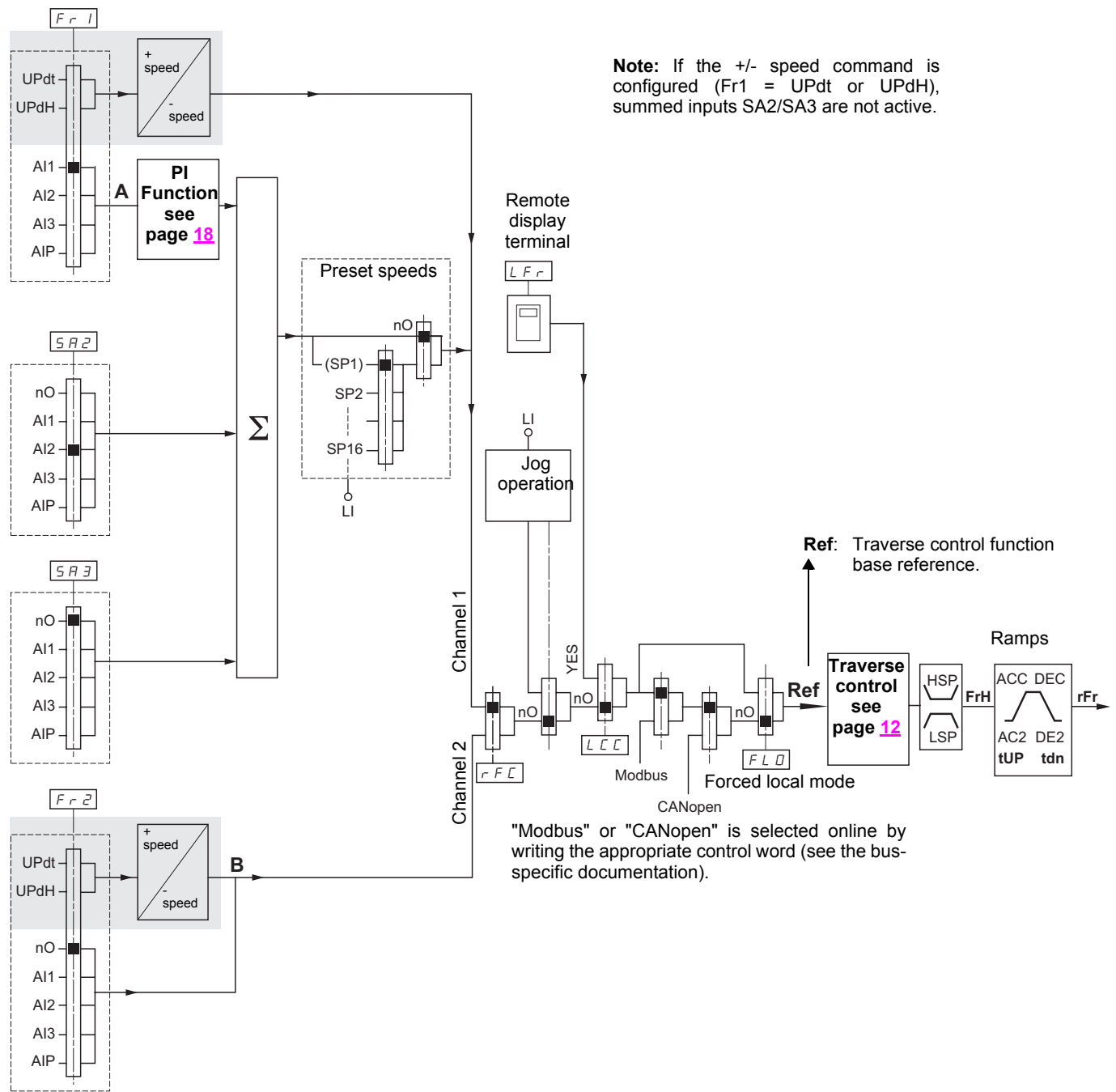

Key:

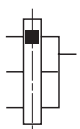

Parameter:
The black square represents
the factory setting assignment



Function accessible for LAC = L2

Control menu CtL-

Reference channel for LAC = L3

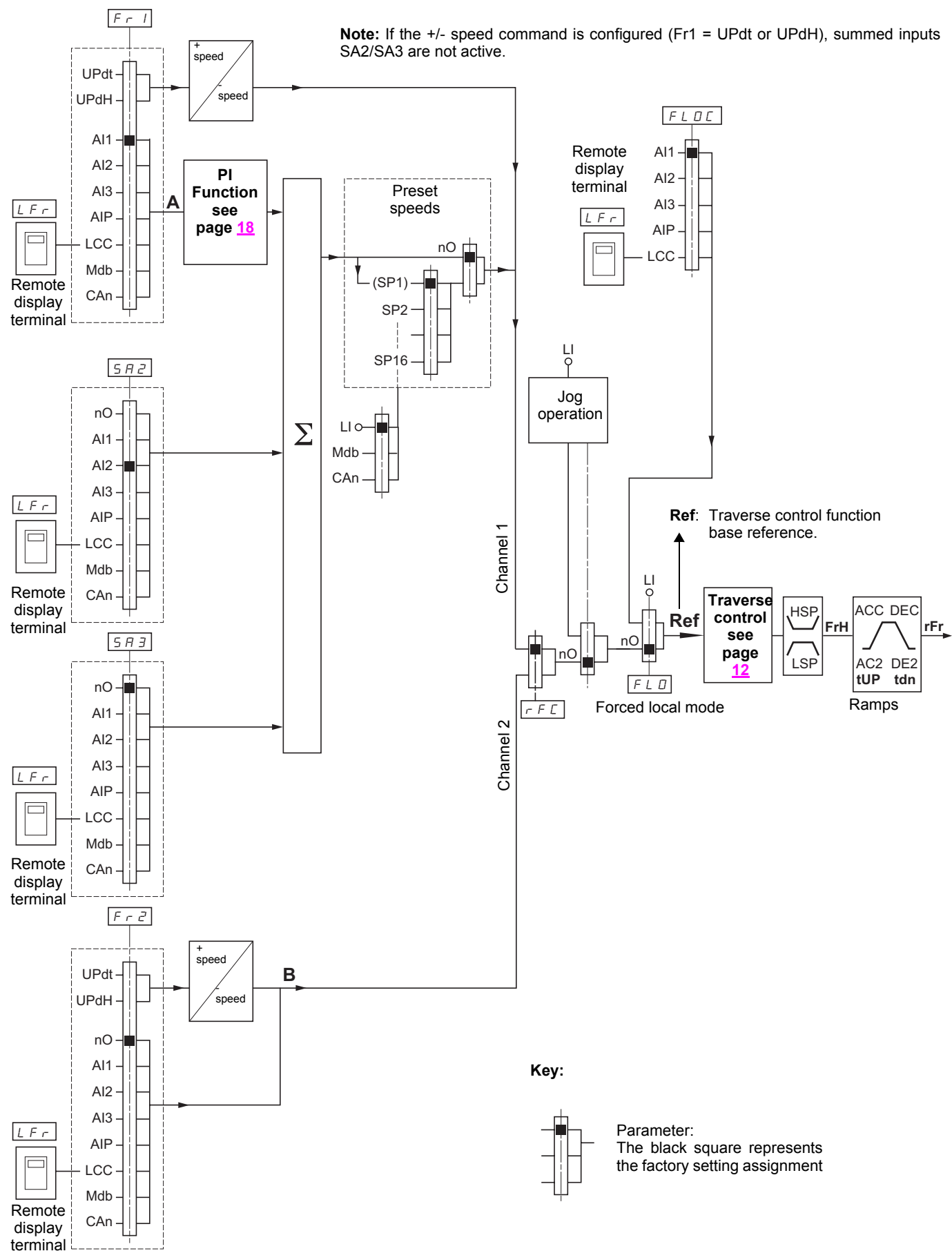

Application functions menu FUn-

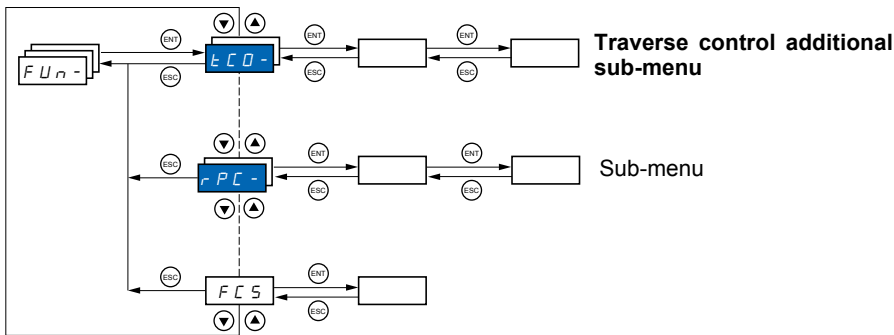

The parameters can only be modified when the drive is stopped and no run command is present. On the optional remote display terminal, this menu can be accessed with the switch in the  position.

Some functions have numerous parameters. In order to clarify programming and avoid having to scroll through endless parameters, these functions have been grouped in sub-menus.

Like menus, sub-menus are identified by a dash after their code:  for example.



There may be an incompatibility between functions (see the incompatibility table page 5). In this case, the first function configured will prevent the remainder being configured.

- | | |
|-----------------------------|---|
| Additional sub-menu: | Traverse control: tCO- |
| Modified sub-menu: | PI regulator: PI- |
| Deleted sub-menus: | Brake control: bLC-
Management of limit switches: LSt- |

Traverse control

Function for winding reels of thread (in textile applications)

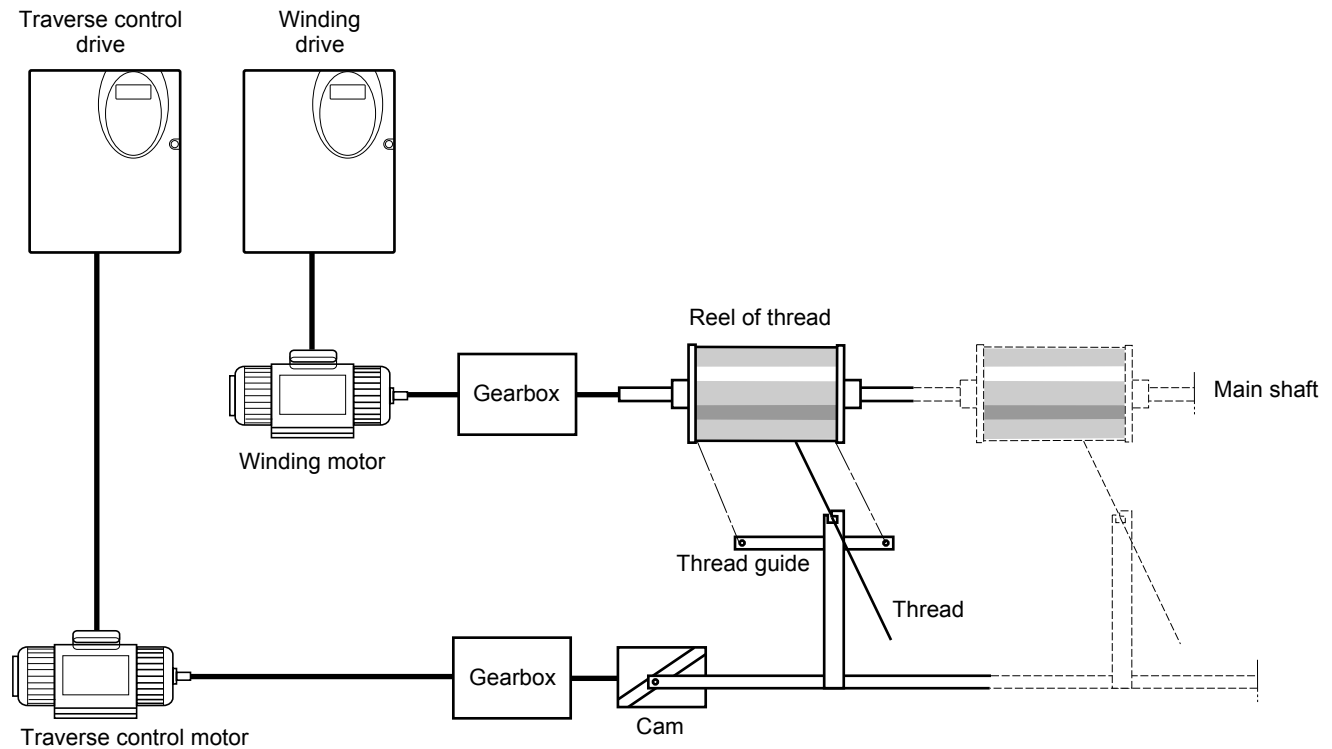

The cam speed of rotation must follow a precise profile to ensure that the reel is steady, compact and linear:

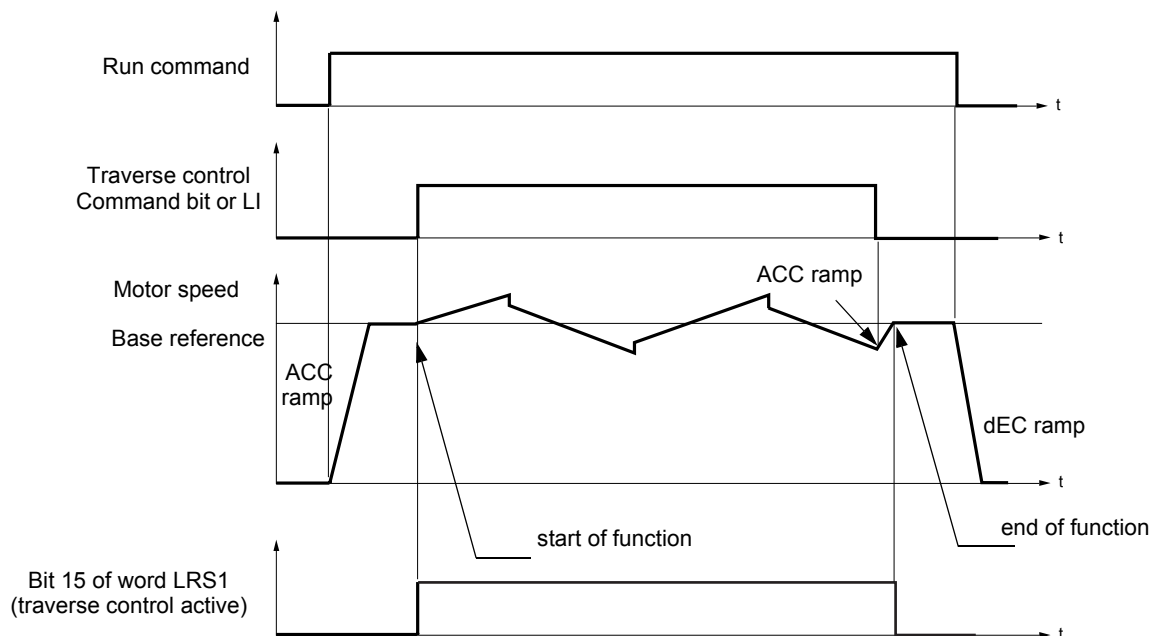

The function starts when the drive has reached its base reference and the traverse control command has been enabled. When the traverse control command is disabled, the drive returns to its base reference, following the drive ACC or dEC ramp. The function then stops, as soon as it has returned to this reference. Bit 15 of word LRS1 is at 1 while the function is active.

Application functions menu FUn-

Function parameters:

They define the cycle of frequency variations around the base reference, as shown in the figure below:

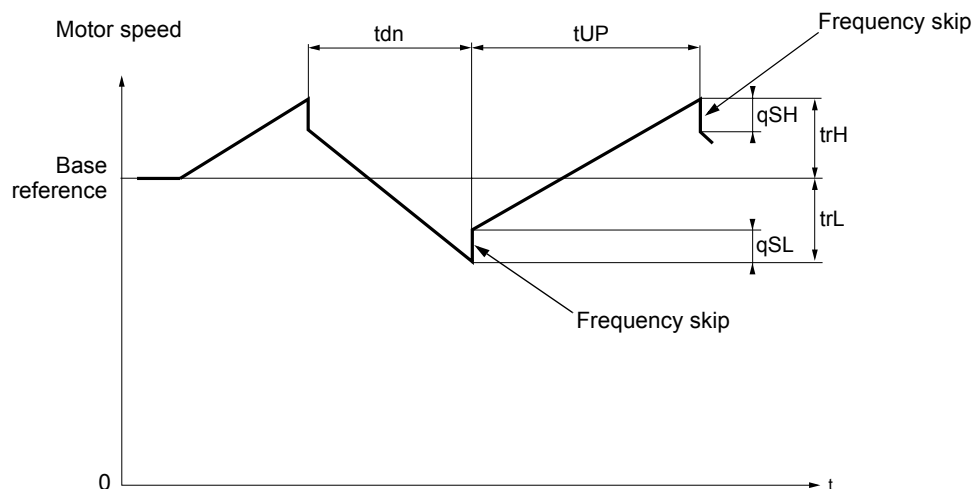

- trC: Traverse control command: Assignment of the traverse control command to a logic input or to a communication bus control word bit
- tdn: Traverse control deceleration time, in seconds
- tUP: Traverse control acceleration time, in seconds
- trH: "traverse frequency high" in Hertz
- trL: "traverse frequency low" in Hertz
- qSH "quick step high" in Hertz
- qSL "quick step low" in Hertz

Reel parameters:

- tbO: Time taken to make a reel, in minutes.
This parameter is intended to signal the end of winding. When the traverse control operating time since command trC reaches the value of tbO, the logic output or one of the relays changes to state 1, if the corresponding function EbO has been assigned in menu I-O-.
The traverse control operating time EbOt can be monitored online by a communication bus and in the Display menu SUP-.
- dtF: Decrease in the base reference.
In certain cases, it is necessary to reduce the base reference as and when the reel increases in size. The value dtF corresponds to the time tbO. Once this time has elapsed, the reference continues to fall, following the same ramp.
If low speed LSP is at 0, the speed reaches 0 Hz, the drive stops and must be reset by a new run command.
If low speed LSP is anything but 0, the traverse control function continues to operate above LSP.

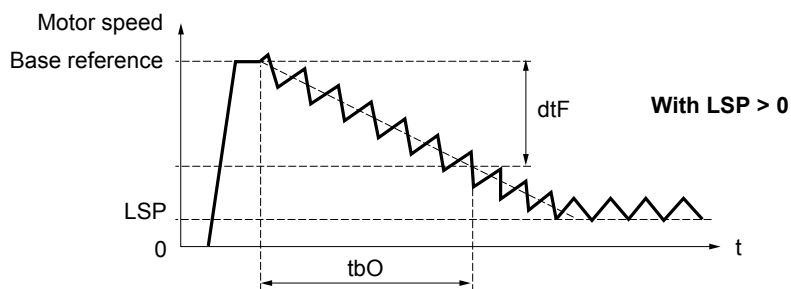
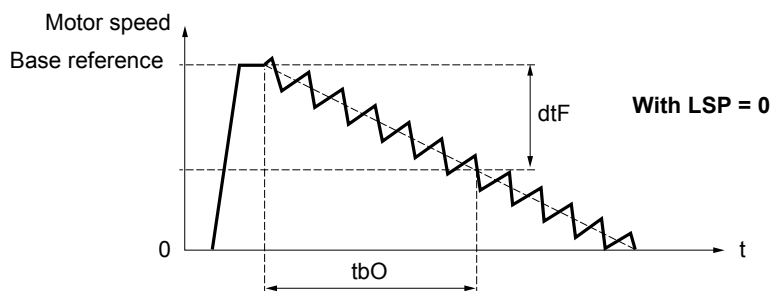

Application functions menu FUn-

- rtr: Traverse control reset
This command can be assigned to a logic input or to a communication bus control word bit. It resets the EbO alarm and the EbOt operating time to zero and reinitializes the reference to the base reference. As long as rtr remains at 1 the traverse control function is inhibited and the speed remains the same as the base reference. This command is mainly used when changing reels.

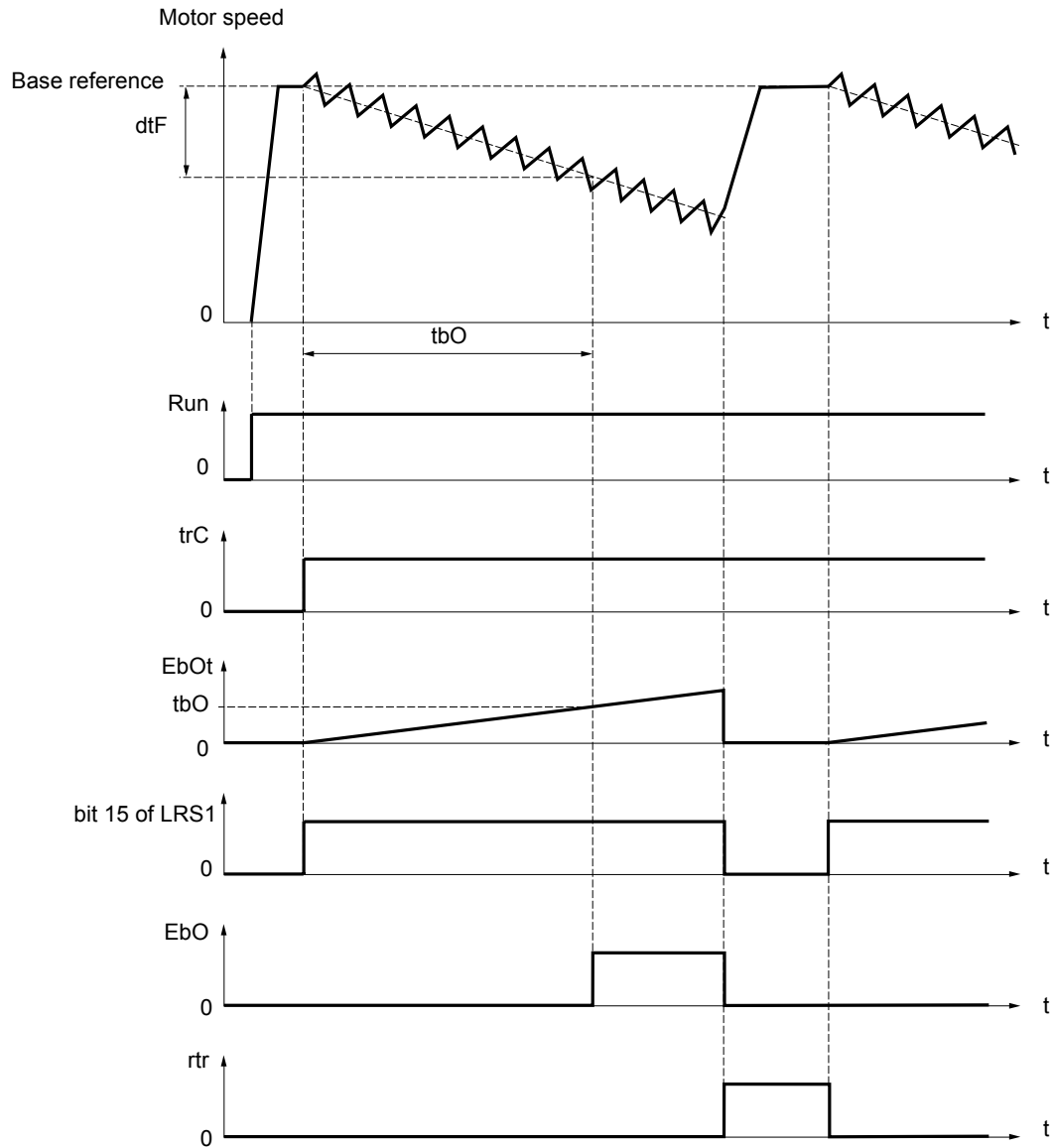

Counter wobble

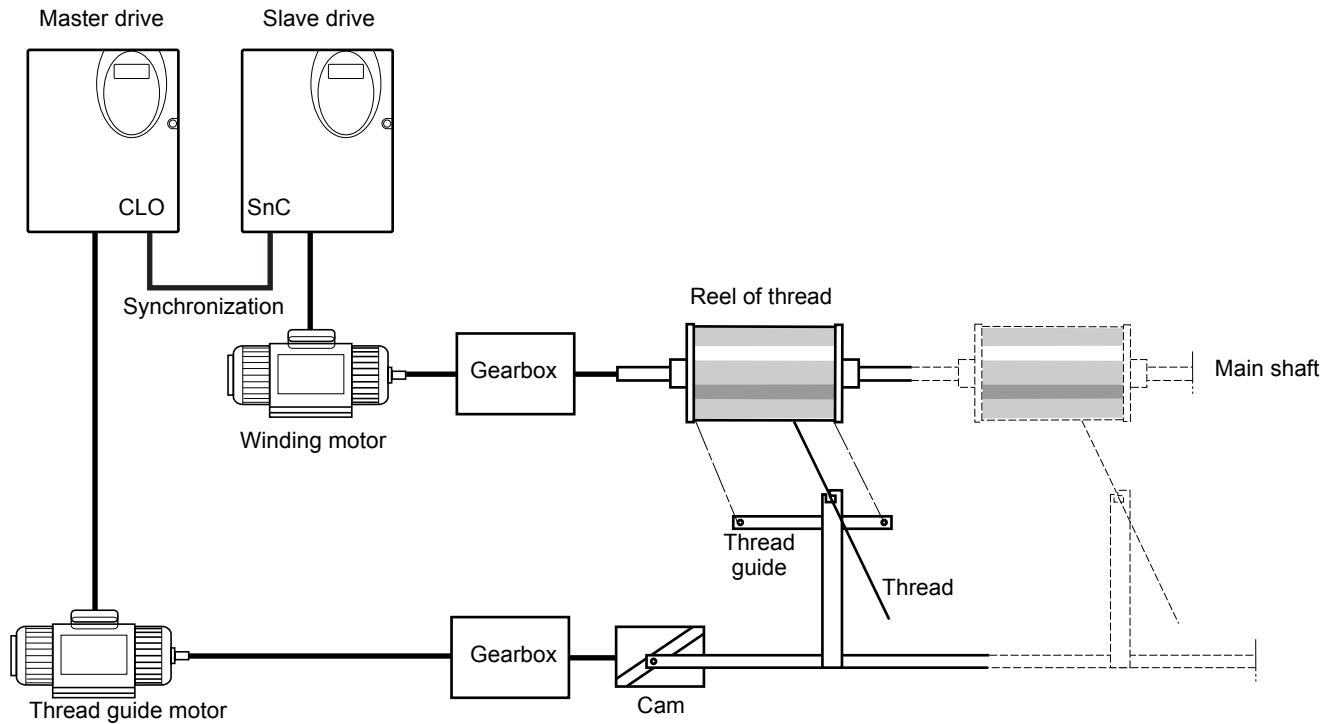

The "Counter wobble" function is used, in certain applications, to obtain a constant thread tension when the Traverse control function causes significant variations in speed on the thread guide motor (trH and trL see page 13).

Two special "Traverse control" drives must be used (a master and a slave).

The master controls the speed of the thread guide, the slave controls the winding speed. The function gives the slave a speed ratio in anti-phase with that of the master. A synchronization operation is therefore necessary, using a master logic output and a slave logic input.

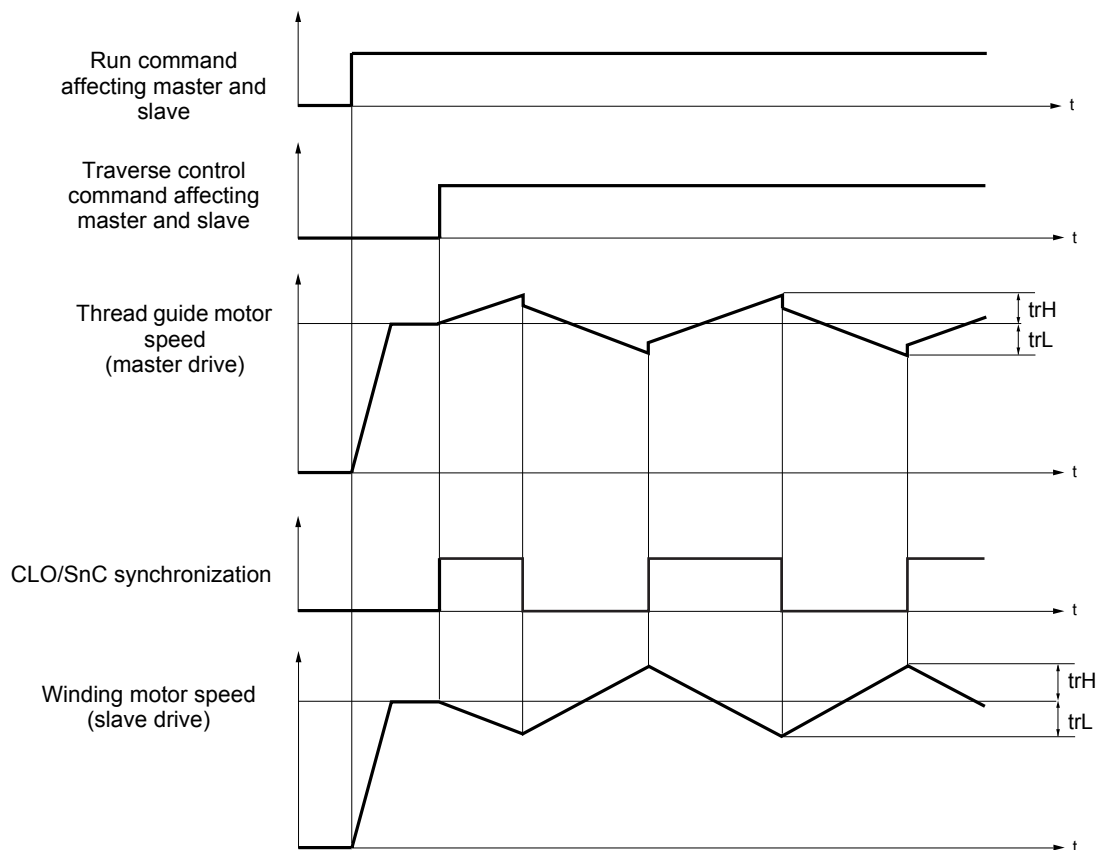

Application functions menu FUn-

Connecting the synchronization I/O

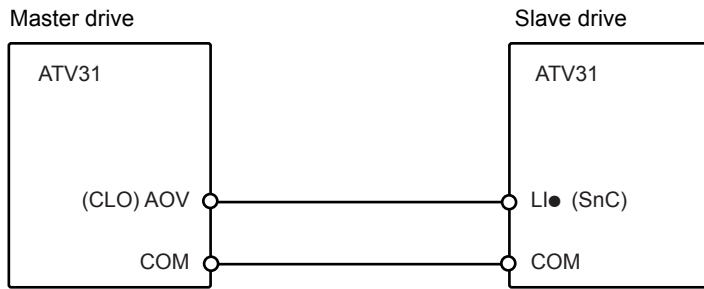

Preferably, logic output AOV should be used.

The starting conditions for the function are:

- Base speeds of both drives reached
- "Traverse control command" input trC activated
- Synchronization signal present

Note: On the slave drive, parameters qSH and qSL should usually be left at zero.

Application functions menu FUN-



Code	Description	Adjustment range	Factory setting
EC0-	Traverse control Caution the "Traverse control" function may be incompatible with other functions (see page 5)		
<i>ErC</i>	Traverse control command <i>nD</i> : Not assigned <i>L11</i> : Logic input LI1 <i>L12</i> : Logic input LI2 <i>L13</i> : Logic input LI3 <i>L14</i> : Logic input LI4 <i>L15</i> : Logic input LI5 <i>L16</i> : Logic input LI6 If LAC = L3, the following assignments are possible: <i>Cd11</i> : Bit 11 of the Modbus or CANopen control word <i>Cd12</i> : Bit 12 of the Modbus or CANopen control word <i>Cd13</i> : Bit 13 of the Modbus or CANopen control word <i>Cd14</i> : Bit 14 of the Modbus or CANopen control word <i>Cd15</i> : Bit 15 of the Modbus or CANopen control word		LI3
<i>ErH</i>	Traverse frequency high (1)	0 to 10 Hz	4 Hz
<i>ErL</i>	Traverse frequency low (1)	0 to 10 Hz	4 Hz
<i>q5H</i>	Quick step high (1)	0 to trH	0 Hz
<i>q5L</i>	Quick step low (1)	0 to trL	0 Hz
<i>EU P</i>	Traverse control acceleration time (1)	0.1 to 999.9 s	4 s
<i>Edn</i>	Traverse control deceleration time (1)	0.1 to 999.9 s	4 s
<i>EBD</i>	Time taken to make a reel (1)	0 to 9999 minutes	0
<i>dEF</i>	Decrease in the base reference (1)	0 to 500 Hz	0
<i>rEr</i>	Traverse control reset <i>nD</i> : Not assigned <i>L11</i> : Logic input LI1 <i>L12</i> : Logic input LI2 <i>L13</i> : Logic input LI3 <i>L14</i> : Logic input LI4 <i>L15</i> : Logic input LI5 <i>L16</i> : Logic input LI6 If LAC = L3, the following assignments are possible: <i>Cd11</i> : Bit 11 of the Modbus or CANopen control word <i>Cd12</i> : Bit 12 of the Modbus or CANopen control word <i>Cd13</i> : Bit 13 of the Modbus or CANopen control word <i>Cd14</i> : Bit 14 of the Modbus or CANopen control word <i>Cd15</i> : Bit 15 of the Modbus or CANopen control word		n0
<i>SnC</i>	"Counter wobble" synchronization <i>nD</i> : Not assigned (function inactive) <i>L11</i> : Logic input LI1 <i>L12</i> : Logic input LI2 <i>L13</i> : Logic input LI3 <i>L14</i> : Logic input LI4 <i>L15</i> : Logic input LI5 <i>L16</i> : Logic input LI6 To be configured on the winding drive (slave) only.		n0

(1)Parameter can be adjusted during operation.



These parameters only appear if the function has been enabled by assignment of trC.

Application functions menu FUN-

PI regulator

Diagram

The function is activated by assigning an analog input to the PI feedback (measurement).

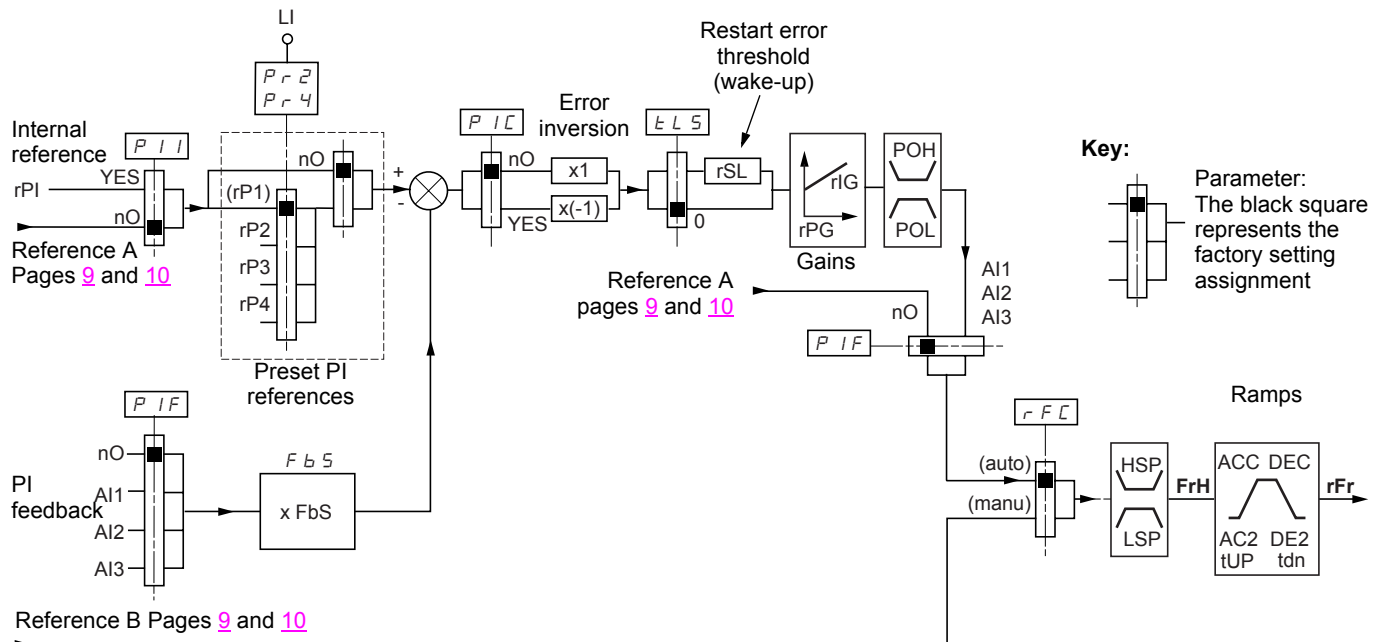

Key:
Parameter:
The black square represents the factory setting assignment

PI feedback:

The PI feedback must be assigned to one of the analog inputs (AI1, AI2 or AI3).

PI reference:

The PI reference can be assigned to the following parameters in order of priority:

- Preset references via logic inputs (rP2, rP3, rP4)
- Internal reference (rPI)
- Reference Fr1

Combination table for preset PI references

LI (Pr4)	LI (Pr2)	Pr2 = nO	Reference
			rPI or Fr1
0	0		rPI or Fr1
0	1		rP2
1	0		rP3
1	1		rP4

Adjustment parameters:

- Internal reference (rPI)
- Preset references (rP2, rP3, rP4)
- Regulator proportional gain (rPG)
- Regulator integral gain (rIG)
- FbS parameter:
The FbS parameter can be used to scale the reference on the basis of the variation range of the PI feedback (sensor rating).
E.g.: Regulation of the thread tension
PI reference (process) 0-5 Newton (0-100%)
Rating of tension sensor 0-10 Newton
FbS = Max. sensor scale/Max. process
FbS = 10/5 = 2
- rSL parameter:
Can be used to set the PI error threshold above which the PI regulator will be reactivated (wake-up) after a stop due to the max. time threshold being exceeded at low speed (tLS).
- Reversal of the direction of correction (PIC): If PIC = nO, the speed of the motor will increase when the error is positive, for example: pressure control with a compressor. If PIC = YES, the speed of the motor will decrease when the error is positive, for example: temperature control via a cooling fan.
- PI regulator min. (OPL) and max. (OPH) outputs.

Parameter which can be accessed in the display menu SUP-:

- PI feedback (rPF).

Application functions menu FUn-

"Manual - Automatic" operation with PI

This function combines the PI regulator and the switching of reference rFC. The speed reference is given by Fr2 or by the PI function, depending on the state of the logic input.

Setting up the PI regulator

1 Configuration in PI mode

See the diagram on page 18.

2 Perform a test in factory settings mode (in most cases, this will be sufficient).

To optimize the drive, adjust rPG or rIG gradually and independently and observe the effect on the PI feedback in relation to the reference.

3 If the factory settings are unstable or the reference is incorrect:

Perform a test with a speed reference in Manual mode (without PI regulator) and with the drive on load for the speed range of the system:

- In steady state, the speed must be stable and comply with the reference and the PI feedback signal must be stable.
- In transient state, the speed must follow the ramp and stabilize quickly and the PI feedback must follow the speed.

If this is not the case, see the settings for the drive and/or sensor signal and cabling.

Switch to PI mode.

Set brA to nO (no auto-adaptation of the ramp).

Set the speed ramps (ACC, dEC) to the minimum permitted by the mechanics without triggering an ObF fault.

Set the integral gain (rIG) to minimum.

Observe the PI feedback and the reference.

Switch the drive ON/OFF a number of times or vary the load or reference rapidly.

Set the proportional gain (rPG) in order to ascertain the ideal compromise between response time and stability in transient phases (slight overshoot and 1 to 2 oscillations before stabilizing).

If the reference varies from the preset value in steady state, gradually increase the integral gain (rIG), reduce the proportional gain (rPG) in the event of instability (pump applications), find a compromise between response time and static precision (see diagram).

Perform in-production tests throughout the reference range.

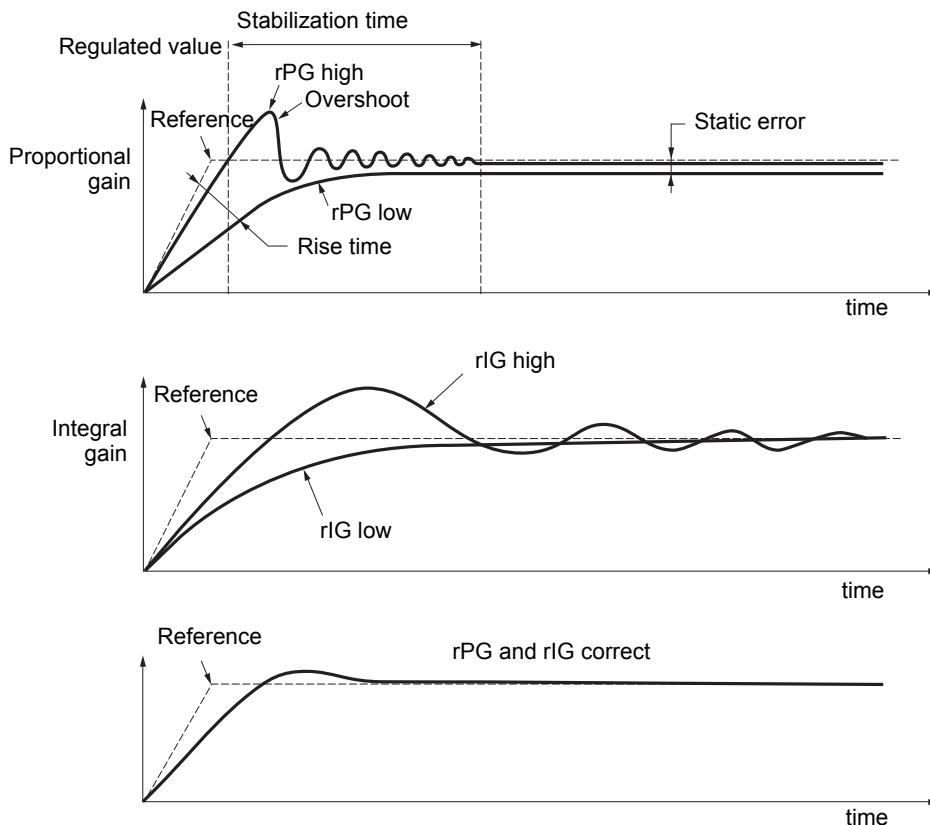

The oscillation frequency depends on the system kinematics.

Parameter	Rise time	Overshoot	Stabilization time	Static error
rPG ↗	↘ ↘	↗	=	↘
rIG ↗	↘	↗ ↗	↗	↘ ↘

Application functions menu FUN-



Code	Description	Adjustment range	Factory setting
PI-	PI regulator		
<i>PIF</i>	PI regulator feedback <i>nD</i> : Not assigned <i>AI1</i> : Analog input AI1 <i>AI2</i> : Analog input AI2 <i>AI3</i> : Analog input AI3		n0
<i>rPG</i>	PI regulator proportional gain (1) Contributes to dynamic performance during rapid changes in the PI feedback.	0.01 to 100	1
<i>rIG</i>	PI regulator integral gain (1) Contributes to static precision during slow changes in the PI feedback.	0.01 to 100	1
<i>Fb5</i>	PI feedback multiplication coefficient (1) For process adaptation	0.1 to 100	1
<i>PIc</i>	Reversal of the direction of correction of the PI regulator (1) <i>nD</i> : normal <i>YES</i> : reverse		n0
<i>Pr2</i>	2 preset PI references Selecting the assigned logic input activates the function. <i>nD</i> : Not assigned <i>L11</i> : Logic input LI1 <i>L12</i> : Logic input LI2 <i>L13</i> : Logic input LI3 <i>L14</i> : Logic input LI4 <i>L15</i> : Logic input LI5 <i>L16</i> : Logic input LI6 If LAC = L3, the following assignments are possible: <i>Cd11</i> : Bit 11 of the Modbus or CANopen control word <i>Cd12</i> : Bit 12 of the Modbus or CANopen control word <i>Cd13</i> : Bit 13 of the Modbus or CANopen control word <i>Cd14</i> : Bit 14 of the Modbus or CANopen control word <i>Cd15</i> : Bit 15 of the Modbus or CANopen control word		n0
<i>Pr4</i>	4 preset PI references Selecting the assigned logic input activates the function. Check that Pr2 has been assigned before assigning Pr4. <i>nD</i> : Not assigned <i>L11</i> : Logic input LI1 <i>L12</i> : Logic input LI2 <i>L13</i> : Logic input LI3 <i>L14</i> : Logic input LI4 <i>L15</i> : Logic input LI5 <i>L16</i> : Logic input LI6 If LAC = L3, the following assignments are possible: <i>Cd11</i> : Bit 11 of the Modbus or CANopen control word <i>Cd12</i> : Bit 12 of the Modbus or CANopen control word <i>Cd13</i> : Bit 13 of the Modbus or CANopen control word <i>Cd14</i> : Bit 14 of the Modbus or CANopen control word <i>Cd15</i> : Bit 15 of the Modbus or CANopen control word		n0
<i>rP2</i>	2nd preset PI reference (1) Only appears if Pr2 has been enabled by selecting an input.	0 to 100%	30%
<i>rP3</i>	3rd preset PI reference (1) Only appears if Pr4 has been enabled by selecting an input.	0 to 100%	60%
<i>rP4</i>	4th preset PI reference (1) Only appears if Pr4 has been enabled by selecting an input.	0 to 100%	90%

(1)Parameter can also be accessed in the settings menu SEt-, and can be adjusted during operation.



These parameters only appear if the function has been enabled by assignment of PIF.

Application functions menu FUn-



Code	Description	Adjustment range	Factory setting	
PI- (continued)	rSL	Restart error threshold ("wake-up" threshold)	0 to 100% 0	
		If the "PI" and "Low speed operating time" tLS functions are configured at the same time, the PI regulator may attempt to set a speed lower than LSP. This results in unsatisfactory operation which consists of starting, operating at low speed then stopping, and so on... Parameter rSL (restart error threshold) can be used to set a minimum PI error threshold for restarting after a stop at prolonged LSP. The function is inactive if tLS = 0.		
	PII	Internal PI regulator reference		n0
		n0 : The PI regulator reference is Fr1, except for UPdH and UPdt (+/- speed cannot be used as the PI regulator reference). YES : The PI regulator reference is internal via parameter rPI.		
	rPI	Internal PI regulator reference (1)	0 to 100%	0
	PQH	PI regulator max. output (2)	0 to 500 Hz 50	
		Maximum value of the regulator output (deadband). The factory setting is 50 Hz, or 60 Hz if bFr is set to 60 Hz.		
	PQL	PI regulator min. output (2)	0 to 500 Hz 0	
		Minimum value of the regulator output, even when there are no errors.		

(1)Parameter can also be accessed in the settings menu SEt-, and can be adjusted during operation.

(2)Parameter can be adjusted during operation



These parameters only appear if the function has been enabled by assignment of PIF.

Display menu SUP-

Additional parameters:

- PI feedback
- Traverse control operating time



Code	Description	Variation range
<i>L F r</i>	Unchanged	
<i>r P I</i>		
<i>r P F</i>	PI feedback	0 to 100%
<i>F r H</i>	Unchanged	
<i>L H d</i>		
<i>E b O t</i>	Traverse control operating time	0 to 9999 minutes
<i>L F t</i> to <i>R I B A</i>	Unchanged	



These parameters only appear if the function has been enabled.

Configuration/Settings table

Application functions menu



Code	Factory setting	Customer setting
EC0 -	ErC LI3	
	ErH 4 Hz	Hz
	ErL 4 Hz	Hz
	q5H 0 Hz	Hz
	q5L 0 Hz	Hz
	tUP 4 s	s
	tDn 4 s	s
	tbd 0 min	min
	dEF 0 Hz	Hz
	rEr nO	
SnC nO		
rPC -	rPE LI1	
	ER1 10%	%
	ER2 10%	%
	ER3 10%	%
	ER4 10%	%
	ACC 3 s	s
	dEC 3 s	s
	rP5 nO	
	FrE 0	Hz
	AC2 5 s	s
	dE2 5 s	s
	brA YES	
	SEc -	SEe rMP
FSE nO		
dCF 4		
dC1 nO		
IdC 0.7 In		A
tDC 0.5 s		s
nSE nO		
AdC -	AdC YES	
	tDC1 0.5 s	s
	SDC1 0.7 In (1)	A
	tDC2 0 s	s
SA1 -	SA2 AI2	
	SA3 nO	
P55 -	P52 If tCC = 2C: LI3 If tCC = 3C: LI4 If tCC = LOC: LI3	
	P54 If tCC = 2C: LI4 If tCC = 3C: nO If tCC = LOC: LI4	
	P5B nO	
	P51B nO	
	SP2 10 Hz	Hz
	SP3 15 Hz	Hz
	SP4 20 Hz	Hz
	SP5 25 Hz	Hz
	SP6 30 Hz	Hz
	SP7 35 Hz	Hz
	SP8 40 Hz	Hz

Code	Factory setting	Customer setting
P55 -	SP9 45 Hz	Hz
	SP10 50 Hz	Hz
	SP11 55 Hz	Hz
	SP12 60 Hz	Hz
	SP13 70 Hz	Hz
	SP14 80 Hz	Hz
	SP15 90 Hz	Hz
	SP16 100 Hz	Hz
	JOG -	JOG If tCC = 2C: nO If tCC = 3C: LI4 If tCC = LOC: nO
JGF 10 Hz		Hz
UPd -	USP nO	
	dSP nO	
	SEr nO	
P1 -	PIF nO	
	rPG 1	
	rIG 1	
	Fb5 1	
	PIc nO	
	Pr2 nO	
	Pr4 nO	
	rP2 30%	%
	rP3 60%	%
	rP4 90%	%
	r5L 0	
	PI1 nO	
	rP1 0%	%
POH 50 Hz	Hz	
POL 0 Hz	Hz	
LC2 -	LC2 nO	
	CL2 1.5 In (1)	A
CHP -	CHP nO	
	Un52 According to drive rating	V
	Fr52 50 Hz	Hz
	nCr2 According to drive rating	A
	nSP2 According to drive rating	RPM
	CO52 According to drive rating	
	UFt2 n	
	UFr2 20%	%
	FLG2 20%	%
	SEr2 20%	%
	SLP2 100 Hz	Hz

(1) In corresponds to the nominal drive current indicated in the installation manual and on the drive rating plate

These parameters only appear if the corresponding function has been enabled. They can be adjusted during operation.

Communication variables

The communication variables user's manual should be used, filling in the following information for the different or additional parameters.

NOTE:

The communication variables are listed with:

- Their address **** in decimal format for Modbus
- Their index and subindex address ****/.. in hexadecimal format for CANopen

Read/write

Whether the parameters have read and/or write access is indicated in the "Read/Write" column with the following codes:

- R: read only, drive stopped or running
- R/WS: read access when drive stopped or running and write access only when drive stopped
- R/W: read and write access when drive stopped or running

The variables or values specific to the **ATV31...T** are underlined.

Monitoring variables

Modbus address	CANopen address	Code	Read/Write	Name/Description/Possible values
3250	2002 / 33	LRS1	R	Extended status word No. 1 bit 0: Reserved bit 1 = 0: No drive fault bit 1 = 1: Drive fault bit 2 = 0: Motor stopped bit 2 = 1: Motor running bit 3: Reserved bit 4 = 0: Frequency threshold (Ftd) not reached bit 4 = 1: Frequency threshold (Ftd) reached bit 5 = 0: High speed not reached bit 5 = 1: High speed reached bit 6 = 0: Current threshold (Ctd) not reached bit 6 = 1: Current threshold (Ctd) reached bit 7 = 0: Speed reference not reached bit 7 = 1: Speed reference reached bit 8 = 0: No motor thermal overload alarm bit 8 = 1: Motor thermal overload alarm <u>bit 9: Reserved</u> bits 10 and 11: Reserved bit 12 = 0: No loss of 4-20 mA fault bit 12 = 1: Loss of 4-20 mA fault bit 13: Reserved bit 14 = 0: No drive thermal overload alarm bit 14 = 1: Drive thermal overload alarm <u>bit 15 = 0: No traverse control</u> <u>bit 15 = 1: Traverse control active</u>
11981	2059 / 52	rPF	R	<u>PI feedback</u> Unit: 0.01%
12209	205C / A	EbOt	R	<u>Traverse control operating time</u> Unit: 1 minute This parameter is reset by command rtr.

Communication variables

Configuration and adjustment variables

Modbus address	CANopen address	Code	Read/Write	Name/Description/Possible values
9607	2042 / 8	UFt	R/WS	Selection of the type of voltage/frequency ratio Factory setting: 0 0 = "L": Constant torque for motors connected in parallel or special motors 1 = "P": Variable torque: Pump and fan applications 2 = "n": Sensorless flux vector control for constant torque applications 3 = "nLd": Energy saving, for variable torque applications not requiring high dynamics (behaves in a similar way to the P ratio at no load and the n ratio on load).
9101	203D / 2	SrF	R/WS	Suppression of the speed loop filter Factory setting: 1 0 = "nO": The speed loop filter is active (prevents the reference being exceeded). 1 = "YES": The speed loop filter is suppressed (in position control applications, this reduces the response time and the reference may be exceeded).
5031	2014 / 20	dO	R/WS	Analog/logic output AOC/AOV Factory setting: 0 0 = "nO": Not assigned For the following assignments the output is analog type: 129 = "OCr": Motor current. 20 mA or 10 V corresponds to twice the nominal drive current. 130 = "OFr": Motor frequency. 20 mA or 10 V corresponds to the maximum frequency tFr 132 = "Otr": Motor torque. 20 mA or 10 V corresponds to twice the nominal motor torque. 139 = "OPr": Power supplied by the drive. 20 mA or 10 V corresponds to twice the nominal drive power For the following assignments the output is logic type (see diagram in the Installation Manual):  With these assignments, configure AO1t = 0A. 1 = "FLt": Drive fault 2 = "rUn": Drive running 4 = "FtA": Frequency threshold reached (Ftd parameter) 5 = "FLA": High speed (HSP) reached 6 = "CtA": Current threshold reached (Ctd parameter) 7 = "SrA": Frequency reference reached 8 = "tSA": Motor thermal threshold reached (ttd parameter) 12 = "APL": Loss of 4-20 mA signal, even if LFL = nO <u>101 = "EbO": End of reel (parameter tbO page 17)</u> <u>102 = "CLO": "Counter wobble" synchronization</u> The logic output is at state 1 (24 V) when the selected assignment is active, with the exception of FLt (state 1 if the drive is not faulty).
5001	2014 / 2	r1	R/WS	Relay r1 Factory setting: 1 0 = "nO": Not assigned 1 = "FLt": Drive fault 2 = "rUn": Drive running 4 = "FtA": Frequency threshold reached (Ftd parameter) 5 = "FLA": High speed (HSP) reached 6 = "CtA": Current threshold reached (Ctd parameter) 7 = "SrA": Frequency reference reached 8 = "tSA": Motor thermal threshold reached (ttd parameter) 12 = "APL": Loss of 4-20 mA signal, even if LFL = nO <u>101 = "EbO": End of reel (parameter tbO page 17)</u> <u>102 = "CLO": "Counter wobble" synchronization</u> The relay is powered up when the selected assignment is active, with the exception of FLt (powered up if the drive is not faulty).

Communication variables

Configuration and adjustment variables

Modbus address	CANopen address	Code	Read/Write	Name/Description/Possible values
5002	2014 / 3	r2	R/W/S	<p>Relay r2 Factory setting: 0 0 = "nO": Not assigned 1 = "FLt": Drive fault 2 = "rUn": Drive running 4 = "FtA": Frequency threshold reached (Ftd parameter) 5 = "FLA": High speed (HSP) reached 6 = "CtA": Current threshold reached (Ctd parameter) 7 = "SrA": Frequency reference reached 8 = "tSA": Motor thermal threshold reached (ttid parameter) 12 = "APL": Loss of 4-20 mA signal, even if LFL = nO 101 = "EbO": End of reel (parameter tbO page 17) 102 = "CLO": "Counter wobble" synchronization The relay is powered up when the selected assignment is active, with the exception of FLt (powered up if the drive is not faulty).</p>
11952	2059 / 35	POL	R/W	<p>PI regulator min. output Unit: 0.1 Hz Factory setting: 0 Adjustment range: 0 to 5000</p>
11953	2059 / 36	POH	R/W	<p>PI regulator max. output Unit: 0.1 Hz Factory setting: 500 if bFr = 50 Hz, 600 if bFr = 60 Hz Adjustment range: 0 to 5000</p>
12201	205C / 2	trC	R/W/S	<p>Traverse control command Factory setting: 0 0 = "nO": Not assigned 129 = "LI1": Logic input LI1 130 = "LI2": Logic input LI2 131 = "LI3": Logic input LI3 132 = "LI4": Logic input LI4 133 = "LI5": Logic input LI5 134 = "LI6": Logic input LI6</p> <p>If LAC = L3, the following assignments are possible:</p> <p>171 = "Cd11": bit 11 of the CMD control word written by Modbus or CANopen 172 = "Cd12": bit 12 of the CMD control word written by Modbus or CANopen 173 = "Cd13": bit 13 of the CMD control word written by Modbus or CANopen 174 = "Cd14": bit 14 of the CMD control word written by Modbus or CANopen 175 = "Cd15": bit 15 of the CMD control word written by Modbus or CANopen</p> <p>The function is activated when the logic state of the input or control word bit is at 1.</p>
12202	205C / 3	trH	R/W	<p>Traverse frequency high Unit: 0.01 Hz Factory setting: 400 Adjustment range: 0 to 1000</p>
12203	205C / 4	trL	R/W	<p>Traverse frequency low Unit: 0.01 Hz Factory setting: 400 Adjustment range: 0 to 1000</p>
12204	205C / 5	qSH	R/W	<p>Quick step high Unit: 0.01 Hz Factory setting: 0 Adjustment range: 0 to trH</p>
12205	205C / 6	qSL	R/W	<p>Quick step low Unit: 0.01 Hz Factory setting: 0 Adjustment range: 0 to trL</p>
12206	205C / 7	tUP	R/W	<p>Traverse control acceleration time Unit: 0.1 s Factory setting: 40 Adjustment range: 1 to 9999</p>

Communication variables

Configuration and adjustment variables

Modbus address	CANopen address	Code	Read/Write	Name/Description/Possible values
12207	205C / 8	tdn	R/W	<u>Traverse control deceleration time</u> Unit: 0.1 s Factory setting: 40 Adjustment range: 1 to 9999
12208	205C / 9	tbO	R/W	<u>Time taken to make a reel</u> Unit: 1 minute Factory setting: 0 Adjustment range: 0 to 9999
12210	205C / B	rtr	R/WS	<u>Traverse control reset</u> Factory setting: 0 0 = "nO": Not assigned 129 = "LI1": Logic input LI1 130 = "LI2": Logic input LI2 131 = "LI3": Logic input LI3 132 = "LI4": Logic input LI4 133 = "LI5": Logic input LI5 134 = "LI6": Logic input LI6 If LAC = L3, the following assignments are possible: 171 = "Cd11": bit 11 of the CMD control word written by Modbus or CANopen 172 = "Cd12": bit 12 of the CMD control word written by Modbus or CANopen 173 = "Cd13": bit 13 of the CMD control word written by Modbus or CANopen 174 = "Cd14": bit 14 of the CMD control word written by Modbus or CANopen 175 = "Cd15": bit 15 of the CMD control word written by Modbus or CANopen The function is activated when the logic state of the input or control word bit is at 1.
12211	205C / C	dtF	R/W	<u>Decrease in the base reference</u> Unit: 0.1 Hz Factory setting: 0 Adjustment range: 0 to 5000
12212	205C / D	SnC	R/WS	<u>"Counter wobble" synchronization</u> Factory setting: 0 0 = "nO": Not assigned 129 = "LI1": Logic input LI1 130 = "LI2": Logic input LI2 131 = "LI3": Logic input LI3 132 = "LI4": Logic input LI4 133 = "LI5": Logic input LI5 134 = "LI6": Logic input LI6 The function is activated when the logic state of the input is at 1.

